

THE POWER HINGE SERIES™

The heavy-duty, super quiet Power Hinges are manufactured with double ball bearings, each pivoting on a 3/4", grounded and tempered, solid stainless steel shaft. Efficiently made by a CNC milling machine, they are designed for industrial applications such as high traffic condominiums and heavy wrought iron or aluminum gates. Power Hinges are not only a safer alternative to conventional square hinges*, they also last longer, perform better, install easier, and are competitively priced. Power Hinges are the new choice in the industry.

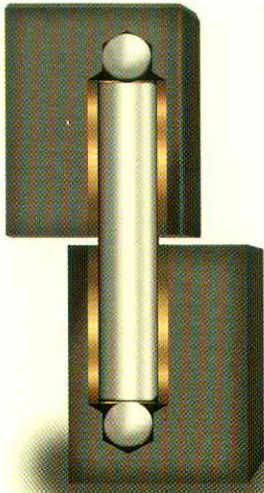

POWER HINGE - SOLID COLD ROLLED STEEL

Constructed of solid steel, for use on steel gates with steel mounting posts.

- COLD ROLLED, SOLID STEEL, HEAVY DUTY HINGE
- DESIGNED FOR A MINIMUM 1.5" GATE FRAME
- TWO 5/8" BALL BEARINGS FOR SMOOTH OPERATION
- 3/4" SOLID STAINLESS STEEL SHAFT, GROUNDED AND TEMPERED TO ROCKWELL STANDARDS
- WEIGHT CAPACITY PER PAIR: 3,000 LBS.
- OPERATION: CONTINUOUS CYCLE
- EASY INSTALLATION
- SUPER QUIET/MAINTENANCE FREE
- SELF LUBRICATION/NO GREASE FITTINGS
- SHIPPING WEIGHT PER PAIR: 11.5 LBS.
- DIMENSIONS: 1.5" X 2.25" X 6.125"

POWER HINGE 2 - COLD ROLLED STEEL / ALUMINUM

Half of this hinge is cold rolled solid steel and the other half is solid aluminum for use on aluminum gates with steel mounting posts.

- 1/2 SOLID STEEL/1/2 ALUMINUM, HEAVY DUTY HINGE
- DESIGNED FOR A MINIMUM 1.5" GATE FRAME
- TWO 5/8" BALL BEARINGS FOR SMOOTH OPERATION
- 3/4" SOLID STAINLESS STEEL SHAFT, GROUNDED AND TEMPERED TO ROCKWELL STANDARDS
- WEIGHT CAPACITY PER PAIR: 1,000 LBS.
- OPERATION: CONTINUOUS CYCLE
- EASY INSTALLATION
- SUPER QUIET/MAINTENANCE FREE
- SELF LUBRICATION/NO GREASE FITTINGS
- SHIPPING WEIGHT PER PAIR: 8 LBS.
- DIMENSIONS: 1.5" X 2.25" X 6.125"

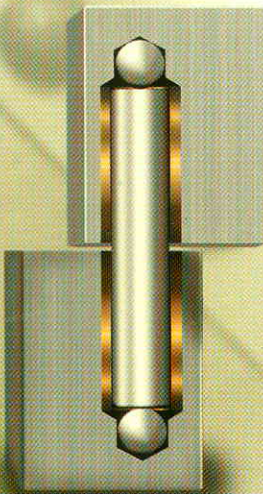
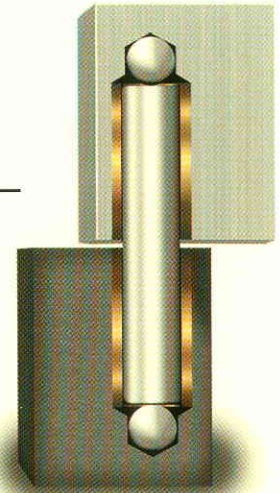

POWER HINGE 3 - ALL ALUMINUM HINGE

Constructed with solid aluminum for use on aluminum gates with aluminum mounting posts.

- HEAVY DUTY, HIGH QUALITY ALUMINUM HINGE
- DESIGNED FOR A MINIMUM 1.5" GATE FRAME
- TWO 5/8" BALL BEARINGS FOR SMOOTH OPERATION
- 3/4" SOLID STAINLESS STEEL SHAFT, GROUNDED AND TEMPERED TO ROCKWELL STANDARDS
- WEIGHT CAPACITY PER PAIR: 1,000 LBS.
- OPERATION: CONTINUOUS CYCLE
- EASY INSTALLATION
- SUPER QUIET/MAINTENANCE FREE
- SELF LUBRICATION/NO GREASE FITTINGS
- SHIPPING WEIGHT PER PAIR: 5 LBS.
- DIMENSIONS: 1.5" X 2.25" X 6.125"

SPECIFICATIONS

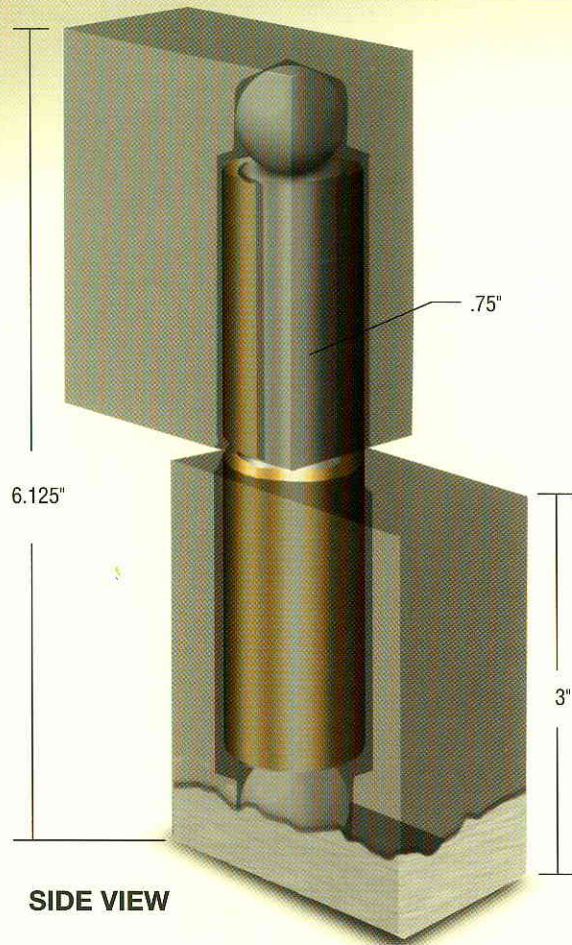
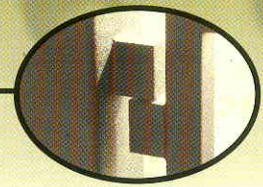

TOP VIEW

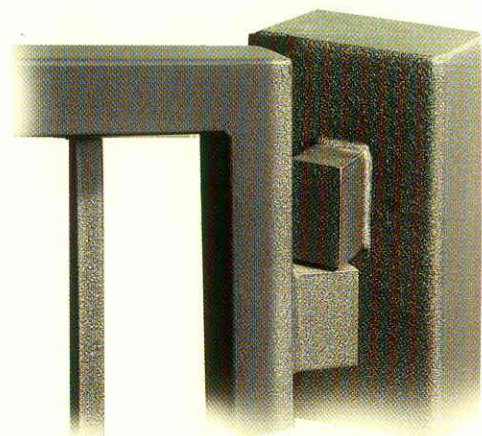
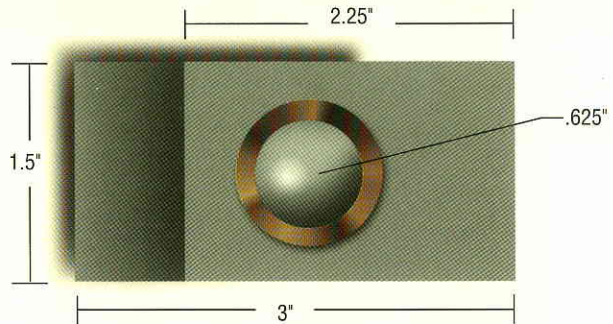

Power Hinges™ are perfect for heavy wrought iron gates as well as other industrial applications.

* POWER HINGE SAFETY FEATURE

CONVENTIONAL HINGE



NO GAP

With conventional square hinges, when the gate opens 90° it hits the post causing wear and tear on the post. This may also cause human hand injury.

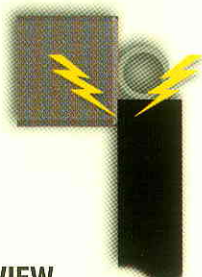

TOP VIEW

POWER HINGE™

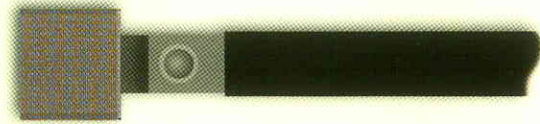

3/4" GAP

Because of the Power Hinge's™ unique shape, the gate never hits the post. When the gate opens to 90°, the hinge is 3/4" away from the post.

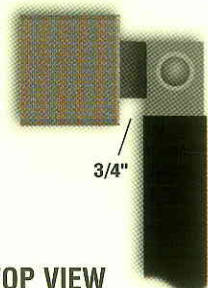

TOP VIEW